

INSTALLATION INSTRUCTIONS

This garage door has been designed to be as easy as possible to use, service and automate when installed correctly. Please therefore take time to read these instructions fully before beginning any work. Note: This door has been designed to hang on a 70mm x 70mm timber goalpost frame (not supplied).



CAUTION

IMPORTANT INFORMATION

- 1 This garage door is intended for domestic use only.
- 2 Garage doors are heavy and may have sharp edges. Wear protective gloves. Installation should not be undertaken alone. Care must be taken when handling.
- 3 Ensure the door is continuously supported before it is secured and avoid installing in windy conditions.
- 4 Do not attempt to install or adjust this door if you are unsure of any of the instructions below.

BEFORE COMMENCING WORK

1 Remove all wrapping

Before starting: remove all wrapping and check door has been supplied with correct lifting gear kit. Kit code is on identification label on reverse of door.

2 Check opening size

Before fitting door, check opening size and squareness of timber frame. The door is made smaller to give correct clearance within the frame.

3 Check headroom

There must be a minimum of 42mm headroom above lower face of top timber or lintel. This must reach back into the garage for at least 1875mm.

4 Check the “goalpost” frame

The “goalpost” timber frame should be a minimum of 70mm x 70mm square ($2\frac{3}{4}$ ” x $2\frac{3}{4}$ ”), in good condition and securely fixed to the surrounding structure.

5 Tools

All the initial fitting work is done from inside the garage, so all tools and parts should be to hand there before door is placed in opening.

You will need:

- 6mm & 10 mm flat bladed screwdriver
- No 2 & 3 posi-drive screwdriver
- Drill and 2.5mm drill bit (for pilot holes)
- 13mm A/F socket/spanner
- 10mm A/F socket/spanner
- 7mm A/F socket/spanner
- Protective gloves
- Sharp knife
- Tape measure
- hammer
- Grease
- Engineer's pliers
- 19mm x 19mm timber weatherbead to fit under the head of the door frame
- 70mm x 70mm timber goal post frame
- Wedges (packing pieces)

Note to installer: Please ensure that this instruction sheet remains with the door for the owner's future reference.

1

CAUTION ! Please ensure all tools and parts are **inside** the garage before the door is placed in the opening.

FITTING YOUR DOOR

Assembly diagram (maximizer door gear illustrated)

Numbers refer to installation notes

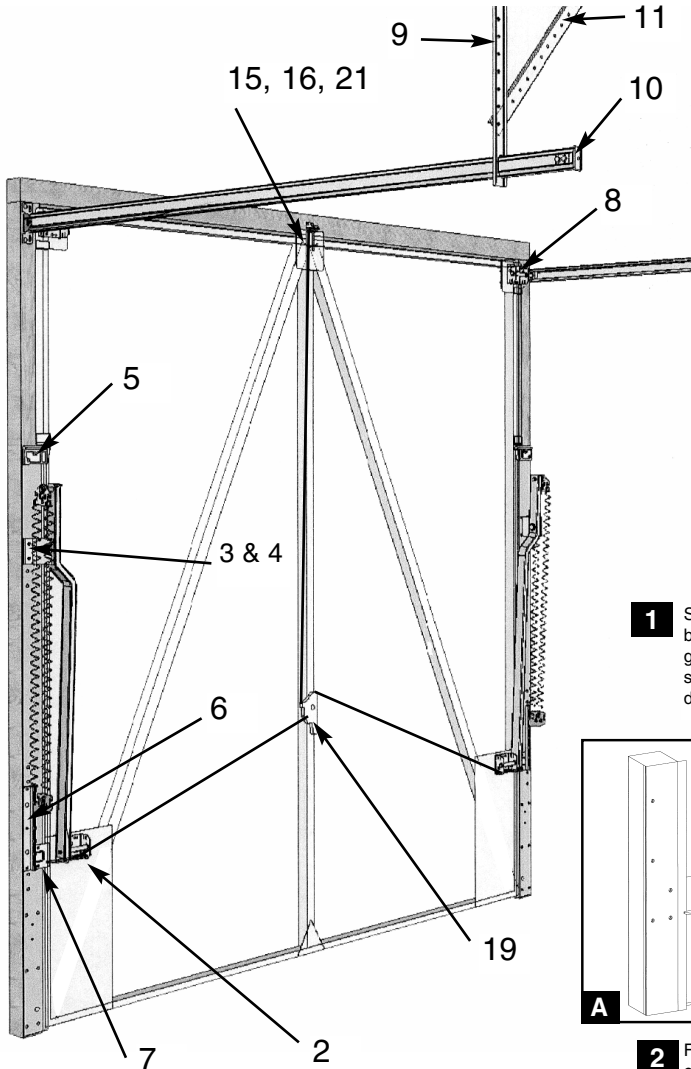

IMPORTANT NOTE

Prior to Fitting the Door

For ease of transportation and storage some doors are supplied without the upper weather strips attached to the door panel. These are supplied separately within the door fixing pack. If your door is of this type then fit the weather strips as shown below using 4 off No. 12 x 3/4" self tapping screws per side

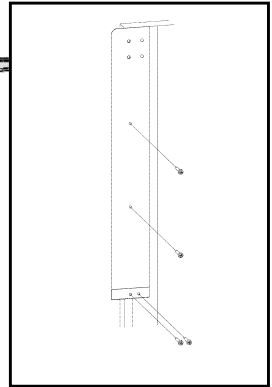

- 1 Stand door, safely propped, centrally between side jambs on two wedges. A gap of approximately 12mm (1/2") should be left between the top of the door and the lintel

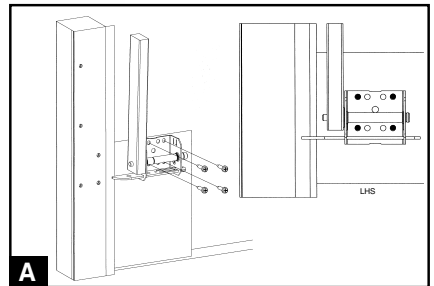

- 2 Fit pivot arms to plates in bottom corners of door using four no. 12 x 3/4" self tapping screws per side Using outer holes shown. (See Figure A)

- 3** Swing the pivot arms up, align two holes in each lower side seal with those in main pivot brackets. Ensure lip on lower side seal locates against side of jamb for full length of side seal. NOTE: for special sized doors the bottom of side seal must be cut short to suit installation.

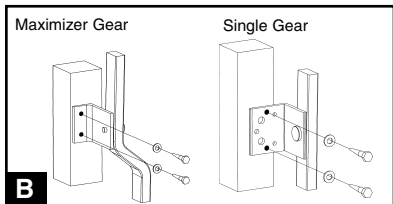

- 4** Drill pilot holes and secure each main pivot bracket using two M8 x 50mm coach screws and two M8 washers per side. (See Fig B)

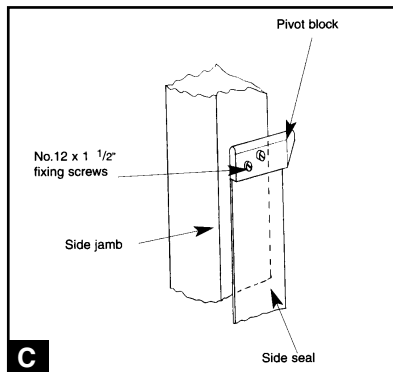

- 5** Smooth lower side seals into position. Align pivot blocks with holes in lower side seals as shown. (Fig. C) drill pilot holes and secure using two no. 12 x 1 1/2": self tapping screws per block.

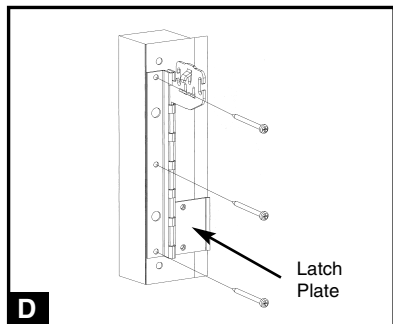

- 6** Smooth lower side seals into position, align holes in lower spring anchor brackets with holes in lower side seals (Fig. D). Secure each bracket using three 6mm x 50mm gold self tapping screw. There is no need to pilot drill for these screws.

- 7** Align holes in latch plates with holes in lower side seals. Drill pilot holes and secure each plate using two no. 12 x 1 1/2" self tapping screws. Cut away flexible lower side seals locally where latch strikes the latch plate

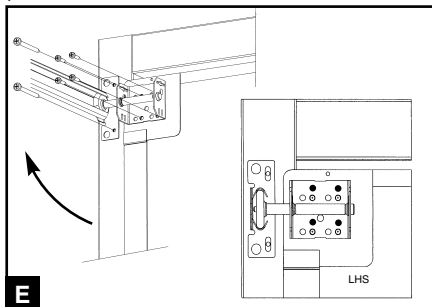

- 8** Fit each wheel bracket to top corner plate of door using four no. 12 x 3/4" self tapping screws ensuring two vertical slots in wheel bracket are facing downwards as shown (Figure E). Slide tracks over wheels and press firmly up and out in the direction of arrow until tracks are horizontal. Drill pilot holes in side jamb and secure each track fixing bracket using two no 12 x 1 1/2" self tapping screws and two M8 washers, ensuring wheel is in contact with the bottom of the track.

- 9** Slide track hangers over ends in orientation shown in main assembly diagram Slide to a convenient roof joist **within 200 mm (8") from end of track** and fix each hanger to joist using ONE no. 12 x 1 1/2" self tapping screw only at this stage. For best results ensure tracks are hanging horizontally, square to the frame and parallel to each other At this stage the tracks should be able to swing sideways.

Slide track end bungs into position in orientation

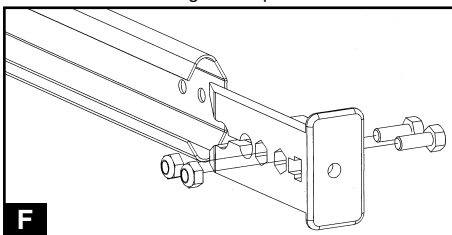

- 10** shown (see Fig. F). Secure each end bung to track using two off M6 x 30mm hexagon head bolts and two M6 nyloc nuts ensuring nuts locate firmly into hexagonal recess in end bung

- 11** Fully open door and prop securely in position. With the door still open the tracks should be parallel. This can be checked by ensuring both roller wheels are in contact with the track end bungs. Bolt track braces to hangers using one M6 x 20mm hexagon head screw and one M6 nyloc nut per side. Fix each track brace to joist using one no.12 x 1 1/2" self tapping screw.

- 12** Lock each track hanger in position by fixing to joist using a second no.12 x 1 1/2" self tapping screw.

- 13** Establish gear setting positions for door from label attached to back of door. **Note** setting 1 is top anchor position

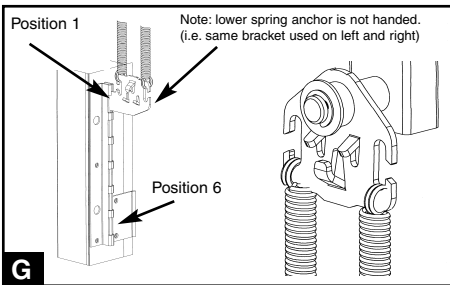

- 14** Still with the door in the open position and wearing eye protection fit lower spring anchors as shown and fit springs to spring anchors in orientation shown (See fig G). **Note Spring loops to be located on anchor bracket hooks facing outwards so that spring body is located in board of spring anchor brackets. When using centre hook spring will require twisting 180 degrees.** Always use the same number of springs on each side. For 2 springs use outer hooks, for 1 spring use centre hook, for 3 springs use all hooks. A minimum of 2 through to maximum of 3 springs per side may be supplied depending upon door weight. Check door operation and re-tension if necessary. (See maintenance label on side seals for details).

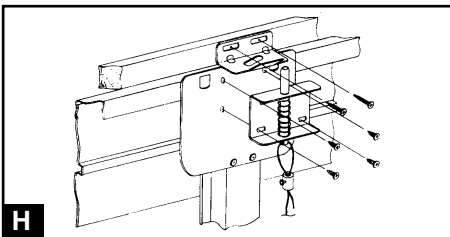

NOTE – Some doors are supplied without the provision for a top latch to be fitted. In these instances the components outlined in instructions 15 & 16 will be surplus to requirements. If your door is of this type proceed to instruction 17.

- 15** Fit the top latch assembly into the pre-drilled holes on the top centre door bracket using 4 off No. 10 x 1/2" self-tapping screws supplied (Figure H).

- 16** With the door closed, remove the park pin to release the latch pin (Figure H) Align the catch bracket centrally over the latch pin with the lower face 3mm (1/8") above the top door bracket.

Insert 2 off No 12 x 1 1/2" self tapping screws through screws slots into head timber, use adjustment on screw slots to ensure correct alignment

- 17** Open the door half way and fit lock following the instructions in the lock pack supplied with your door.

- 18** From front of door ensure that lock handle is turned fully anti-clockwise. From inside slide lock cam onto spindle in orientation shown

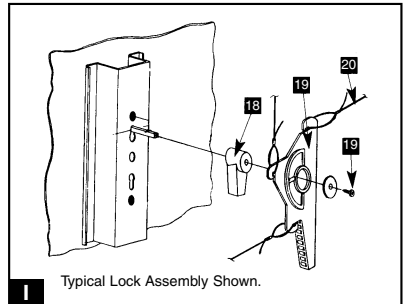

- 19** Fit lock lever onto lock cam as shown and secure to lock spindle using self tapping screw and washer. (See Figure I)

- 20** Locate looped ends of all latch cables securely in lever slots and adjust for correct operation



- 21** **ENGAGEMENT NOTE** On adjustment of top latch, please ensure a nominal 6mm (1/4") pin engagement through catch bracket (Figure J). Adjustment of other latches should also be set to 6 mm latch overlap.

- 22** Check operation from inside garage to avoid being locked out

2

UPON COMPLETION

- 1** Fix lower side seals into position using five 1" clout nails per side.
- 2** Check door operation to ensure door opens and closes satisfactorily.
- 3** Check that lock and latches operate correctly.
- 4** Ensure all fixings are securely tightened
- 5** Fit 19mm × 19mm timber weatherbead to the underside of the top timber lintel (Fig K).
- 6** Do not paint the spring or any moving parts.
- 7** Lubricate all moving parts/pivot points (refer to maintenance label for details) lubrication is an essential ongoing requirement to ensure the continuing smooth operation of your door.
- 8** Ask your professional Garage Door Specialist about remote controlled electric operators.

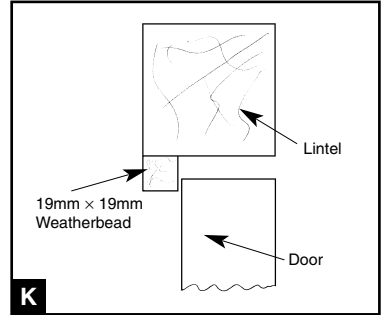

TROUBLE SHOOTING

- **DOOR IS HEAVY TO OPEN:**
Cause: Spring tension set too low
Solution: Re-set spring tension as detailed on the door maintenance label.
- **DOOR OPENS TOO QUICKLY:**
Causes: Spring tension set too high.
Solution: Re-set spring tension as detailed on the door maintenance label.
- **DOOR DOES NOT DELATCH:**
Cause: Latch cables may have been set too long.
Solution: If you are not locked out of the garage at the time, then the cables should be set to allow nominal 6mm latch engagement with the latch plates. If you are locked out of the garage, call your installer/supplier for assistance.
- **DOOR HANDLE FAILS TO TURN:**
Probable Cause: A jammed lock barrel.
Solution: Unfortunately this can only be remedied by a service call, however, this is not usually chargeable during the warranty period. Please contact your supplier for details.
- **KEY FAILS TO TURN IN LOCK:**
Probable Cause: Door handle has not been turned to the fully closed position.
Solution: Return the handle to the fully closed (horizontal) position and try again. If the problem still persists, contact your supplier.
- **LOST KEYS:**
Solution: Contact your supplier. The lock barrel will need to be replaced, but the method for doing this will vary. If you can get into your garage, the problem can be easily solved by removing the handle assembly from the door and replacing the lock barrel with a new one. If you are locked out, contact your supplier.

POWER OPERATION

This door is suitable for power operation. In order to conform with current legislation only independently tested and certified operators may be fitted. A list of approved operators is contained on the Declaration of Incorporation supplied with your door.

DISMANTLING INSTRUCTIONS

THESE INSTRUCTIONS MUST BE FOLLOWED CAREFULLY

GARAGE DOORS ARE HEAVY AND AWKWARD TO HANDLE. ENSURE ASSISTANCE IS AVAILABLE AND THAT SAFETY GLOVES ARE WORN.

1. Fix all latches in the fully retracted position.
2. Open door and safely prop in the open position.
3. Remove springs from their hangers. (wear eye protection).
4. With assistance remove prop and close door slowly until fully closed.
5. Prop door in fully closed position and place packers beneath the door between base of door and floor.
6. Remove all track supports and remove track fixing screws from the frame and remove.
7. Remove fixings to main pivot brackets, door should now rest on packers.
8. Remove bottom door mounting brackets.
9. Remove main pivot blocks.
10. The door can now be carefully removed from the opening. Seek assistance in lifting.
11. If door is to be disposed of please do so in a responsible manner in line with the latest legislation applicable at the time.

**In the event of difficulty please contact your local Garage Door Specialist or call our
Garage Door Helpline.
See main CE label for details**