



CARDALE
GARAGE DOORS



INSTALLATION INSTRUCTIONS FOR YOUR CARDALE **MAXI-MIZER** DOOR

Thank you for choosing a quality Cardale product. This garage door has been designed to be as easy as possible to use, service and automate when installed correctly. Please therefore take time to read these instructions fully before beginning any work. Note: This door has been designed to hang on a 70mm x 70mm timber goalpost frame (not supplied). A separate set of instructions (DPIN 0471) should be used if the door has been supplied pre-fitted to a Cardale quick – fit steel frame.

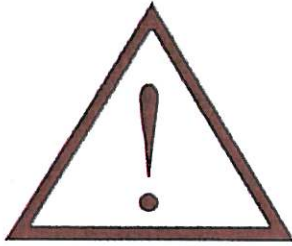

CAUTION

IMPORTANT INFORMATION

- 1 This garage door is intended for domestic use only.
- 2 Garage doors are heavy and may have sharp edges. Wear protective gloves. Installation should not be undertaken alone. Care must be taken when handling.
- 3 Ensure the door is continuously supported before it is secured and avoid installing in windy conditions.
- 4 Do not attempt to install or adjust this door if you are unsure of any of the instructions below.

BEFORE COMMENCING WORK

1 Remove all wrapping

Before starting: remove all wrapping and check door has been supplied with correct lifting gear kit. Kit code is on identification label on reverse of door.

2 Check opening size

Before fitting door, check opening size and squareness of timber frame. The door is made smaller to give correct clearance within the frame.

3 Check headroom

There must be a minimum of 42mm headroom above lower face of top timber or lintel. This must reach back into the garage for at least 1824mm.

4 Check the “goalpost” frame

The “goalpost” timber frame should be a minimum of 70mm x 70mm square (2³/₄” x 2³/₄”), in good condition and securely fixed to the surrounding structure.

5 Tools

All the initial fitting work is done from inside the garage, so all tools and parts should be to hand there before door is placed in opening.

You will need:

- | | |
|----------------------------------------------------------------------------------------------------------------------------------------------------------------------------------------------------------------------------------------------------------------------------------------------------------------------------------------|------------------------------------------------------------------------------------------------------------------------------------------------------------------------------------------------------------------------------------------------------------------------------------------------------|
| <ul style="list-style-type: none"> • 6mm spade end screwdriver • 10mm spade end screwdriver • Drill and 2.5mm drill bit (for pilot holes) • 13mm A/F socket/spanner • 10mm A/F socket/spanner • 7mm A/F socket/spanner • Protective gloves • Sharp knife | <ul style="list-style-type: none"> • Tape measure • Hammer • Grease • Engineer's pliers • 19mm x 19mm timber weatherbead to fit under the head of the door frame • 70mm x 70mm timber goal post frame • Wedges (packing pieces) |
|----------------------------------------------------------------------------------------------------------------------------------------------------------------------------------------------------------------------------------------------------------------------------------------------------------------------------------------|------------------------------------------------------------------------------------------------------------------------------------------------------------------------------------------------------------------------------------------------------------------------------------------------------|

Note to installer: Please ensure that this instruction sheet remains with the door for the owner's future reference.

1

CAUTION! Please ensure all tools and parts are **inside** the garage before the door is placed in the opening.

FITTING YOUR DOOR

Assembly diagram (numbers refer to installation notes)

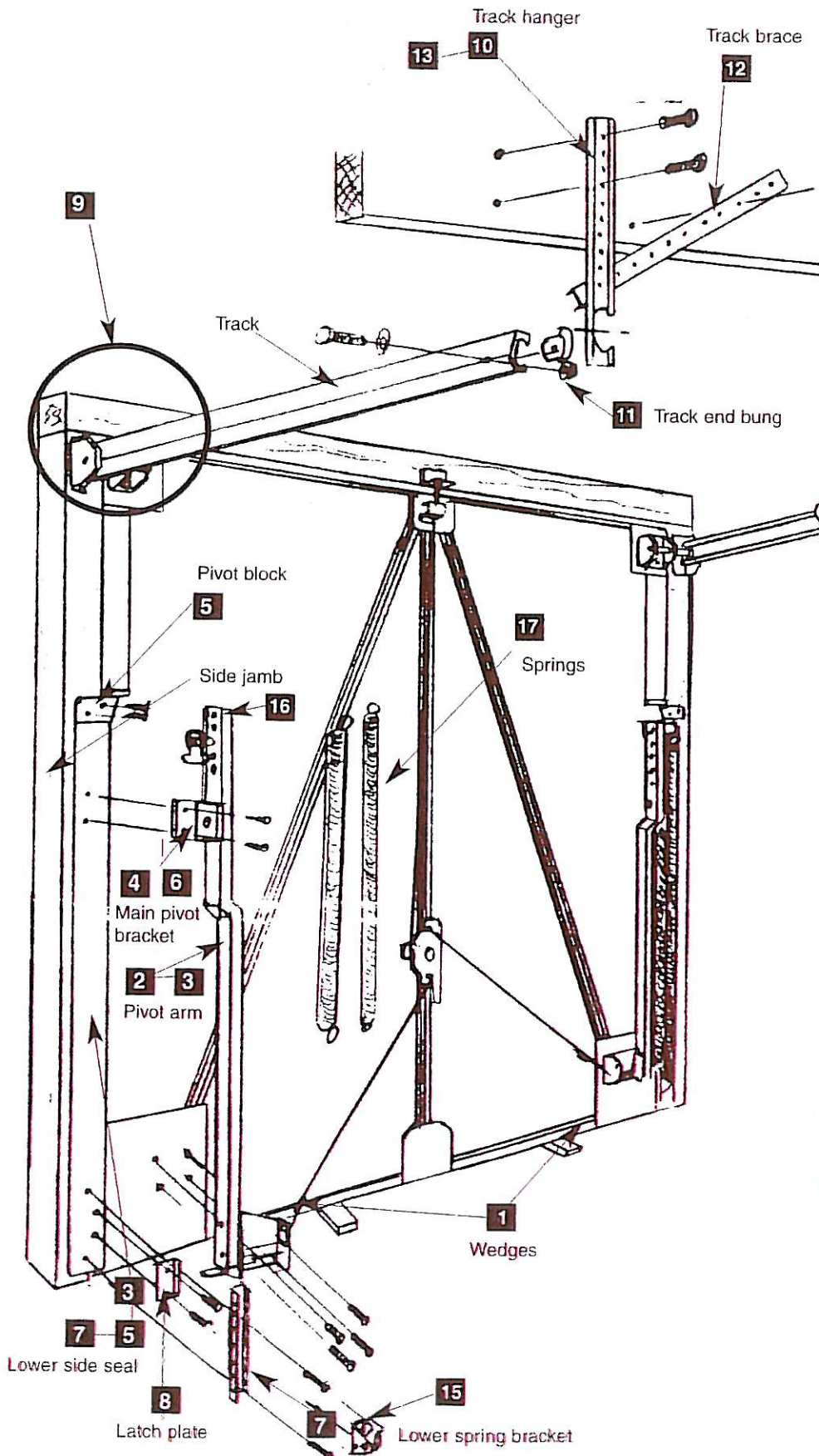

1 Stand door, safely propped, centrally between side jambs on two wedges. A gap of approximately 12mm (1/2") should be left between the top of the door and the lintel.

2 Fit pivot arms to plates in bottom corners of door using four no.10 x 3/4" self tapping screws per side (See Figure A).

3 Swing the pivot arms up, align two holes in each lower side seal with those in main pivot brackets. Ensure lip on lower side seal locates against side of jamb for full length of side seal.

NOTE: For special sized doors the bottom of side seal must be cut short to suit installation.

4 Drill pilot holes and secure each main pivot bracket using two M8 x 50mm coach screws. Do not fully tighten screws at this stage.

5 Smooth lower side seals into position. Align pivot blocks with holes in lower side seals as shown, (Fig.B) drill pilot holes and secure using two no.12 x 1 1/2" self tapping screws per block.

6 Fully tighten screws securing main pivot brackets.

7 Smooth lower side seals into position, align top and bottom holes in lower spring brackets with holes in lower side seals (Fig C) ensuring brackets are correct way up. Drill pilot holes and secure each bracket using two special 6mm x 40mm yellow self tapping screws.

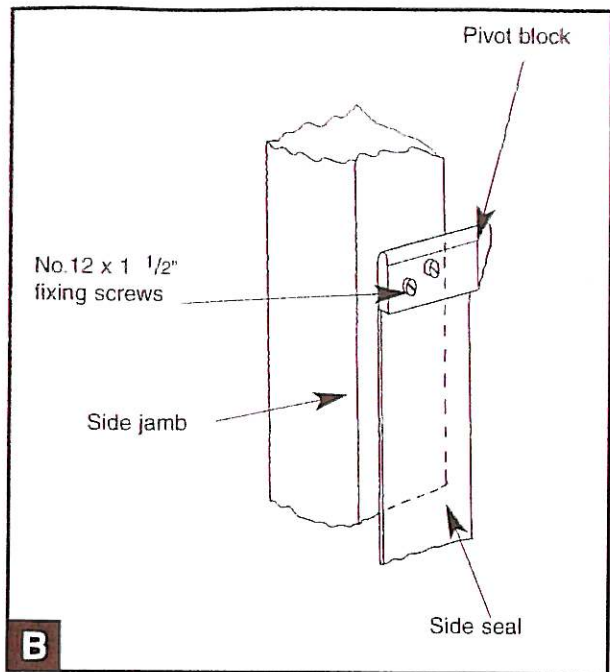
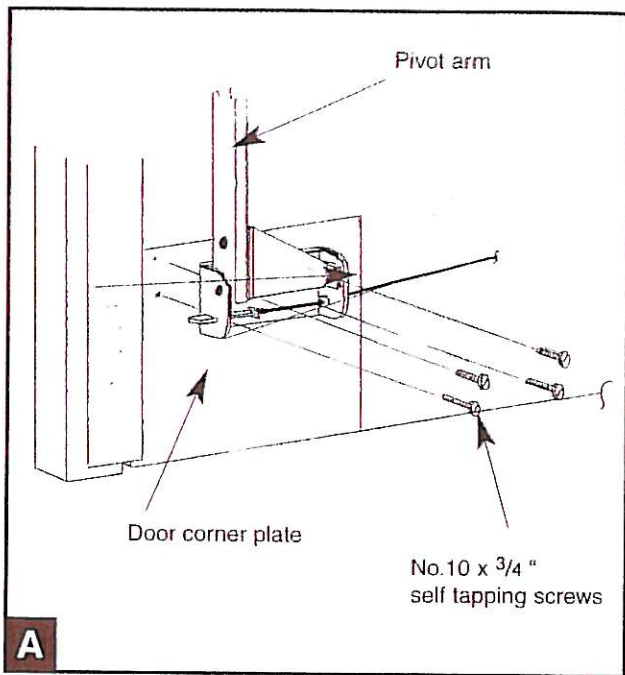

8 Align holes in latch plates with holes in lower side seals. Drill pilot holes and secure each plate using two no.12 x 1 1/2" self tapping screws. Cut away exposed part of side seal from under latch plate and discard.

9 Fit each wheel bracket to top corner plate of door using four no.10 x 3/4" self tapping screws as shown (Figure D). Slide tracks over wheels and press firmly up and out in the direction of arrow until tracks are horizontal. Drill pilot holes in side jambs and secure each track fixing bracket using two no.12 x 1 1/2" self tapping screws and two M8 washers.

10 Slide track hangers over ends in orientation shown in main assembly diagram. Slide to a convenient roof joist and fix each hanger to joist using ONE no.12 x 1 1/2" self tapping screw only at this stage. For best results ensure tracks are hanging horizontally, square to the frame and parallel to each other. At this stage the tracks should be able to swing sideways.

11 Slide track end bungs into position in orientation shown (see Fig.E). Secure each end bung to track using one M6 x 20mm hexagon head screw, one M6 nyloc nut and one M8 washer ensuring nut locates firmly into hexagonal recess in end bung.

12 Fully open door and prop securely in position. With the door still open the tracks should be parallel. This can be checked by ensuring both roller wheels are in contact with the track end bungs. Bolt track braces to hangers using one M6 x 20mm hexagon head screw and one M6 nyloc nut per side. Fix each track brace to joist using one no.12 x 1 1/2" self tapping screw.

13 Lock each track hanger in position by fixing to joist using a second no.12 x 1 1/2" self tapping screw.

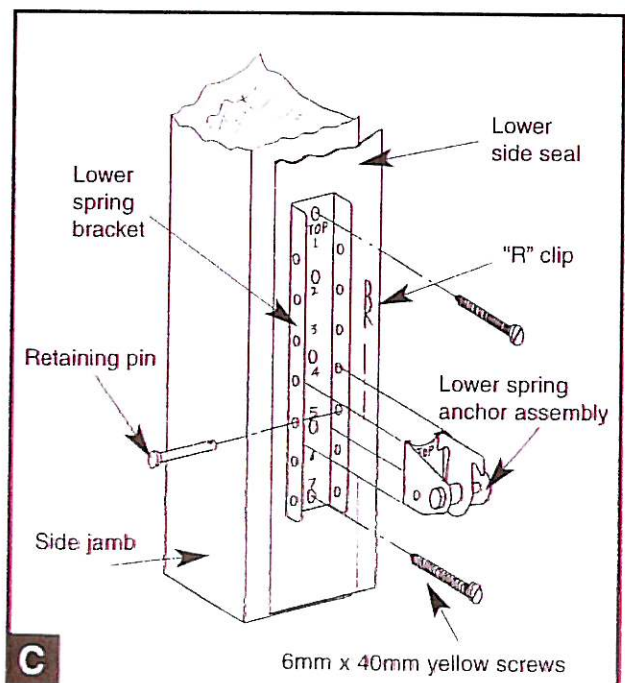

14 Establish gear setting positions for door from label attached to back of door. Letter refers to pin position in arm, number refers to anchor position in lower spring bracket (Figure C & F).

15 Remove retaining pin from each lower spring anchor assembly, locate assemblies in lower spring brackets in position detailed on label.
IMPORTANT: It is vital that the assembly is fitted correct way up (Figure C). Secure in position using retaining pin and "R" clip (See Figure C).
NOTE: retaining pins should be fitted with heads on door opening side of brackets.

16 Remove "R" clips from top spring anchor assemblies and fit to arm as shown in position detailed on label on reverse of door (See Figure F).

17 Fit springs to spring hangers as shown with the loops facing one another (Figure F).
NOTE: - Always fit spring nearest side jamb first.

18 Check that all bolts and screws are fully tightened and "R" clips are correctly engaged.

19 Check door operation and re-tension if necessary. See retensioning instructions on reverse of this instruction sheet.

20 **IMPORTANT SAFETY NOTE**
When tension is correctly set, bend back straight leg on all "R" clips to ensure they cannot be inadvertently removed.

21 Fit the top latch assembly into the pre-drilled holes on the top centre door bracket using 4 off No. 10 x 1/2" self-tapping screws supplied (Figure G).

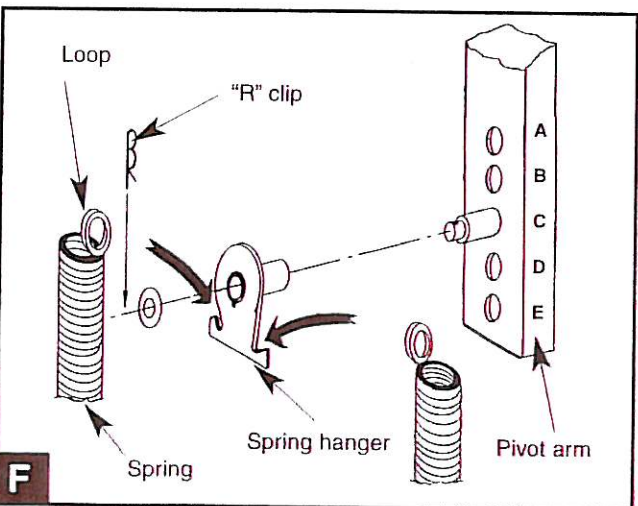
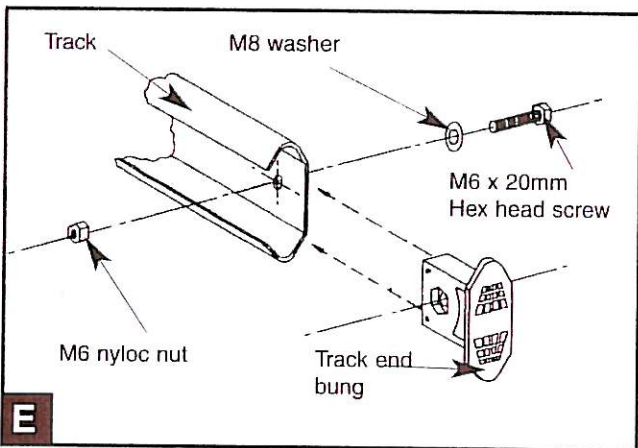
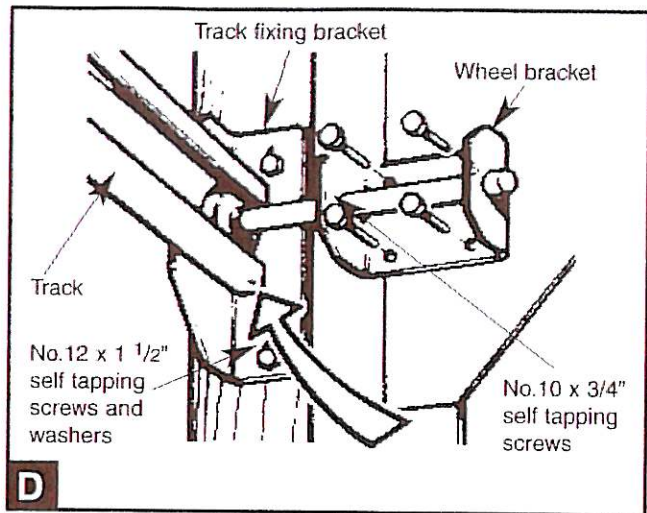

22 With the door closed, remove the park pin to release the latch pin (figure G). Align the catch bracket centrally over the latch pin with the lower face 3mm (1/8") above the top door bracket.
 Insert 2 off No. 12 x 1.1/2" self tapping screws through screws slots into head timber, use adjustment on screw slots to ensure correct alignment.

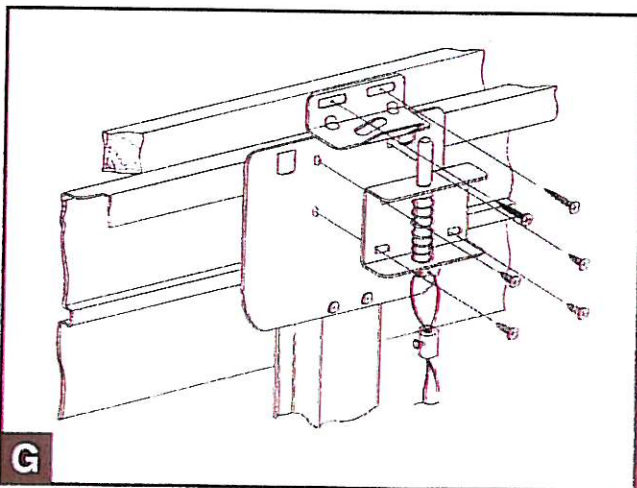

2

FITTING THE LOCK TO YOUR DOOR

Doors supplied with flat lock spacer:

- 1 Insert round lock spacers in outer holes in stiffener as shown.
- 2 Slide flat lock spacer between stiffener and panel as shown in Figure J, lining up holes in spacer with those in panel, ensuring flat face of spacer is against bottom of stiffener.
- 3 From outer face of door insert lock in pre-drilled holes locating the lugs on the lock through the holes in the flat spacer.
- 4 From inside garage insert pan head screws and washers as shown and secure firmly. DO NOT OVERTIGHTEN.
- 5 From front of door ensure that lock handle is turned fully anti-clockwise. From inside slide lock cam onto lock spindle in orientation shown.
- 6 Fit lock lever into lock cam as shown and secure to lock spindle using self tapping screw and washer.
- 7 Locate looped ends of all latch cables securely in lever slots and adjust for correct operation.
- 8 **ENGAGEMENT NOTE.** On adjustment of top latch, please ensure a nominal 6mm (1/4") pin engagement through catch bracket (Figure H).
- 9 Check operation from inside garage to avoid being locked out.

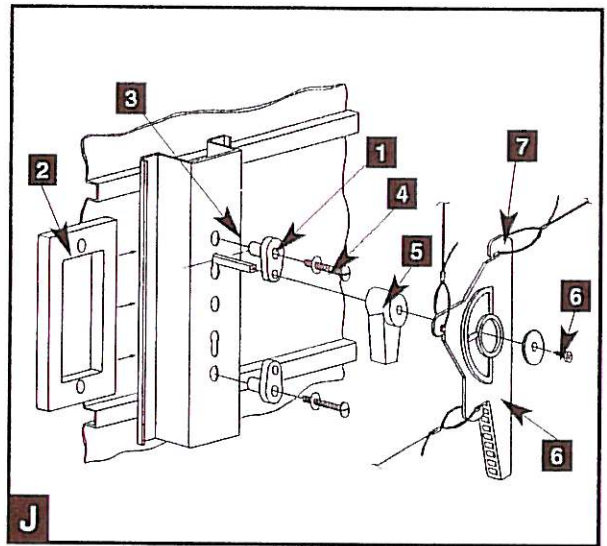
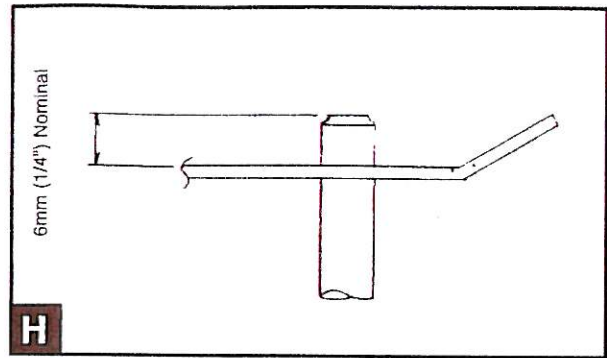

Doors supplied with long round plastic lock spacers:

- 1 Insert spacers through outer pierced holes in stiffener from inside face of garage door as shown in Figure K.
- 2 From outer face of door insert lock into pre-drilled holes locating the lugs on the lock through the holes in the spacers.
- 3 From inside garage, insert pan head screws with washers and secure lock firmly but DO NOT OVERTIGHTEN.
- 4 From front of door ensure that lock handle is turned fully anticlockwise. From inside slide lock cam onto lock spindle in orientation shown.
- 5 Fit lock lever onto lock cam as shown and secure to lock spindle using self tapping screw and washer.
- 6 Locate looped ends of all latch cables securely in lever slots and adjust for correct operation.
- 7 **ENGAGEMENT NOTE.** On adjustment of top latch, please ensure a nominal 6mm (1/4") pin engagement through catch bracket (Figure H).
- 8 Check operation from inside garage to avoid being locked out.

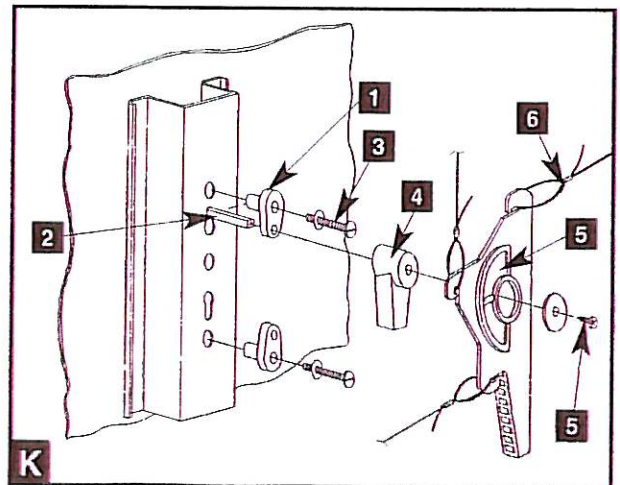

Doors supplied without plastic lock spacers:

- 1** Insert lock from front of door through holes as shown in Figure L, and secure from inside garage using two pan head screws with washers. Secure firmly. But **DO NOT OVERTIGHTEN**.
- 2** From front of door ensure that lock handle is turned fully anti-clockwise. From inside slide lock cam onto spindle in orientation shown.
- 3** Fit lock lever onto lock cam as shown and secure to lock spindle using self tapping screw and washer.
- 4** Locate looped ends of all latch cables securely in lever slots and adjust for correct operation.
- 5** **ENGAGEMENT NOTE.** On adjustment of top latch, please ensure a nominal 6mm (1/4") pin engagement through catch bracket (Figure H).
- 6** Check operation from inside garage to avoid being locked out.

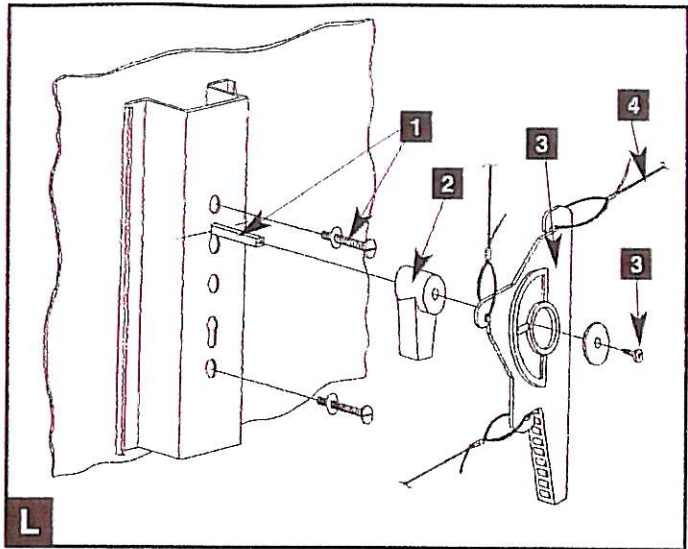

Milford and Berkeley doors:

- 1** From outer face of door insert lock into lock aperture as shown in Figure M.
- 2** Position lock spacers on lugs as shown.
- 3** From inside garage insert pan head screws with washers and secure lock firmly but **DO NOT OVERTIGHTEN**.
- 4** From front of door ensure that lock handle is turned fully anticlockwise. From inside slide lock cam onto lock spindle in orientation shown.
- 5** Fit lock lever onto lock cam as shown and secure to lock spindle using self tapping screw and washer.
- 6** Locate looped ends of all latch cables securely in lever slots and adjust for correct operation.
- 7** **ENGAGEMENT NOTE.** On adjustment of top latch, please ensure a nominal 6mm (1/4") pin engagement through catch bracket (Figure H).
- 8** Check operation from inside garage to avoid being locked out.
- 9** Repeat steps 1 to 3 only for second lock (for appearance only).

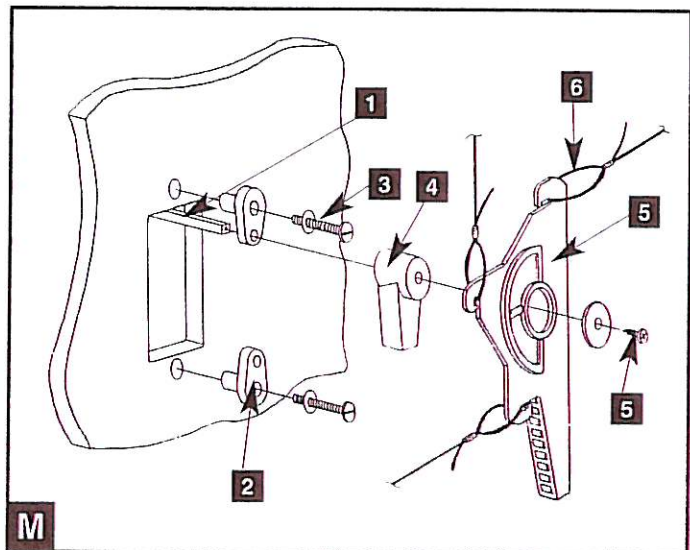

3

UPON COMPLETION

- 1** Fix lower side seals into position using five 1" clout nails per side.
- 2** Lubricate all moving parts/pivot points using the sachet of oil provided.
- 3** For doors 6'6" high or less, we recommend that an extra 6mm x 40mm yellow screw is fitted in each lower spring bracket to help maintain a safe fixing should the timber frame begin to decay.
- 4** **IMPORTANT** Ensure R clips have been bent back.
- 5** Check door operation to ensure door opens and closes satisfactorily. Ensure all fixings are securely tightened.
- 6** Check that lock and latches operate correctly.
- 7** Fit 19mm x 19mm timber weatherbead to the underside of the top timber lintel (Fig N).
- 8** Lubricate all moving parts regularly (refer to lubrication maintenance label on lower side seal).
- 9** Do not paint the spring or any moving parts.
- 10** Ask your professional Cardale Agent about remote controlled electric operators.

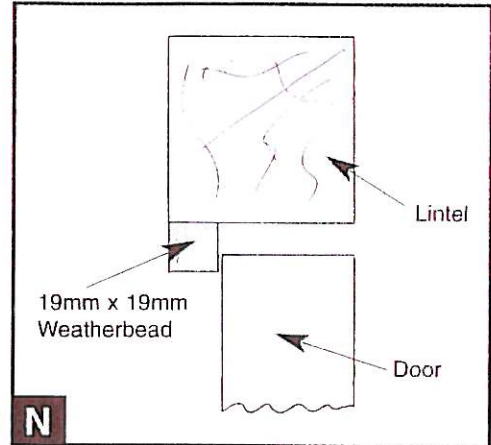

4

TROUBLESHOOTING

•Door is heavy to open:

Cause: Spring tension set too low

Solution: Re-set spring tension as detailed on the reverse of this instruction sheet.

•Door opens too quickly:

Causes: spring tension set too high.

Solution: Re-set spring tension as detailed on the reverse of this instruction sheet.

• Door does not delatch:

Cause: Latch cables may have been set too long.

Solution: If you are not locked out of the garage at the time, then the cables should be set to allow nominal 6mm latch engagement with the latch plates. If you are locked out of the garage, call your installer/supplier for assistance.

• Door handle fails to turn:

Probable Cause: A jammed lock barrel.

Solution: Unfortunately this can only be remedied by a service call, however, this is not usually chargeable during the warranty period. Please contact your supplier for details.

• Key fails to turn in lock:

Probable Cause: Door handle has not been turned to the fully closed position.

Solution: Return the handle to the fully closed (horizontal) position and try again. If the problem still persists, contact your supplier.

• Lost keys:

Solution: Contact your supplier. The lock barrel will need to be replaced, but the method for doing this will vary. If you can get into your garage, the problem can be easily solved by removing the handle assembly from the door and replacing the lock barrel with a new one. If you are locked out, contact your supplier.



RETENSIONING INSTRUCTIONS FOR YOUR CARDALE *MAXI-MIZER* DOOR



IMPORTANT INFORMATION

1. Before proceeding oil all pivot points.
This may prevent the need for re-tensioning.
2. **CAUTION:** THE SPRINGS ARE UNDER TENSION – FOLLOW THESE INSTRUCTIONS CAREFULLY TO AVOID PERSONAL INJURY.
3. Eye protection must be worn.
4. Do not attempt to adjust the spring tension if you are unsure of any of the points below
5. Keep children away from the door whilst spring adjustments are being made.

These instructions must be retained by the householder.

Occasional adjustment of spring tension may be required to maintain smooth door operation.

- 1 Open door fully and secure safely in the open position.
- 2 Remove both springs from spring hangers on one side only.
- 3 Move lower spring anchor assembly up or down to adjacent hole as required. Up reduces tension, down increases tension.
- 4 Re-fit springs.

NEVER MOVE SPRING POSITION MORE THAN ONE HOLE WITHOUT TESTING THE EFFECT ON DOOR OPERATION.

- 5 Repeat operations 1 to 4 on other side
- 6 Ensure both sides are balanced (i.e spring anchor assembly is in same hole on both sides.)
- 7 Release and test door operation.

- 8 **IMPORTANT SAFETY NOTE**
When tension is correctly set, bend back straight leg on all 'R' clips to ensure they cannot be inadvertently removed.

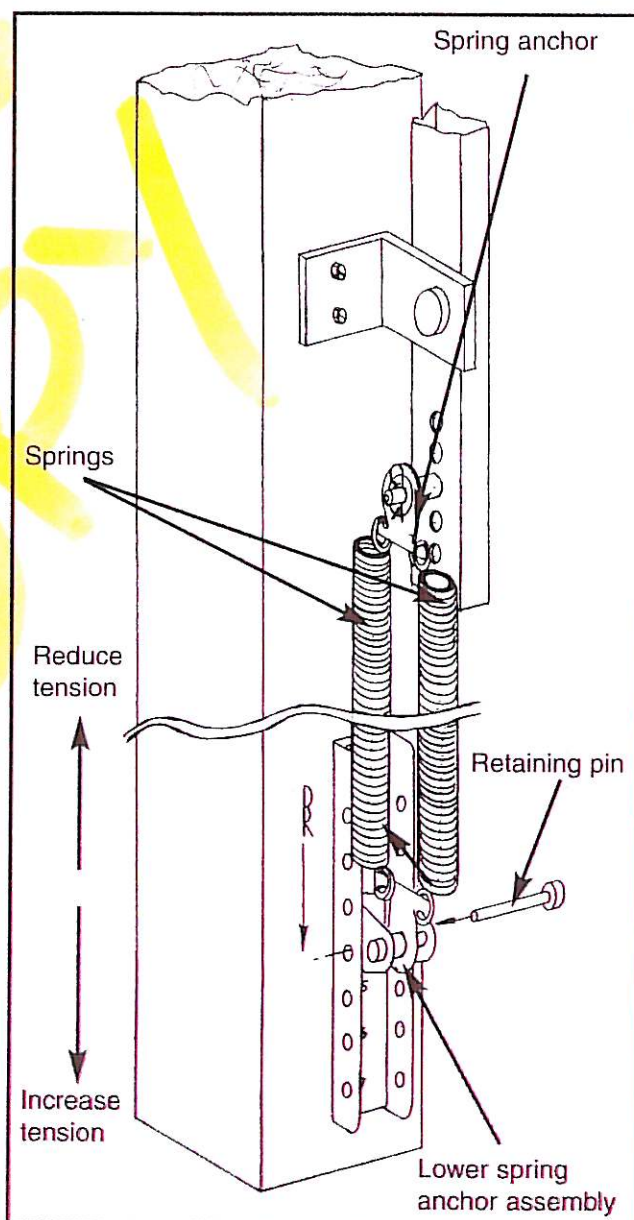

In the event of difficulty please contact your local Cardale Agent.
See Yellow Pages for details.